

AC and DC Plug-in type **AQ-F RELAYS**

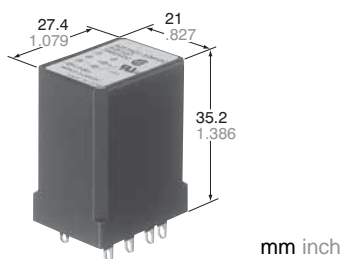

FEATURES

- Suitable for high-capacity and high-frequency switching
- Same size, same terminal arrangement as HC relay
Sockets for HC relays are applicable
- Two load types available: DC output type (2 A, 3 A)
AC output type (2 A, 3 A)
- Wide range of input voltage: 3 V to 28 V

TYPICAL APPLICATIONS

Drive for small-sized motor, heater, solenoid and electromagnetic valves.

- NC machine
- Printing machine
- Machine tool
- Robot for industrial use
- Wrapping and packing machine

TYPES

	Type	Part No.
AC output	Zero-cross 2 A	AQF2A2-ZT3/28VDC
	Zero-cross 3 A	AQF3A2-ZT3/28VDC
DC output	2 A	AQF2AD1-3/28VDC
	3 A	AQF3AD1-3/28VDC

SPECIFICATIONS

Ratings (at 20°C 68°F, Input voltage ripple: 1% or less)

Item	Type	AC output		DC output		Remarks
		AQF2A2-ZT3/28VDC	AQF3A2-ZT3/28VDC	AQF2AD1-3/28VDC	AQF3AD1-3/28VDC	
Input side	Input voltage	3 to 28 V DC				
	Input impedance	Approx. 1.6 kΩ (3 to 28 V DC)				
	Drop-out voltage, min.	0.8 V DC				
Load side	Max. load current	2 A	3 A	2 A	3 A	See "REFERENCE DATA 1" on the following page
	Load voltage	75 to 250 V AC		3 to 60 V DC		
	Non-repetitive surge current	80 A		5 A	6 A	AC: In one cycle at 60 Hz DC: 1 s
	Max. "OFF-state" leakage current	5 mA		1 mA		AC: at 60 Hz 200 V DC: at 60 V
	Max. "ON-state" voltage drop	1.6 V				at max. carrying current
	Min. load current	50 mA		5 mA		

Characteristics (at 20°C 68°F, Input voltage ripple: 1% or less)

Item	Type	AC output		DC output		Remarks
		AQF2A2-ZT3/28 VDC	AQF3A2-ZT3/28 VDC	AQF2AD1-3/28 VDC	AQF3AD1-3/28 VDC	
Operate time max.		(1/2 cycle of voltage sine wave) + 1 ms		0.5 ms		
Release time, max.		(1/2 cycle of voltage sine wave) + 1 ms		2 ms		
Insulation resistance, min.		100 MΩ between input and output				Initial at 500 V DC
Breakdown voltage		2,000 Vrms between input and output				Initial for 1 min.
Vibration resistance	Functional	10 to 55 Hz double amplitude of 3 mm				10 min. for X, Y, Z axes
	Destructive	10 to 55 Hz double amplitude of 3 mm				1 hour for X, Y, Z axes
Shock resistance	Functional	Min. 980 m/s ² {100 G}				4 times each for X, Y, Z axes
	Destructive	Min. 980 m/s ² {100 G}				5 times each for X, Y, Z axes
Ambient temperature		-30°C to +80°C -22°F to +176°F				
Storage temperature		-30°C to +100°C -22°F to +212°F				
Operational method		Zero-cross (Turn-ON and Turn-OFF)		—		

OPERATING PRINCIPLE

Internal circuit
AC output type

Waveform of input and output (Resistive load)

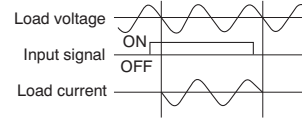
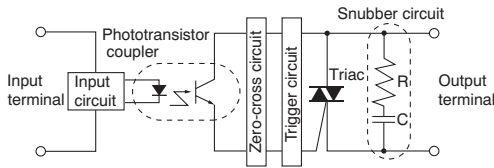

DC output type

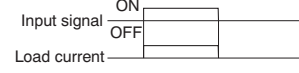
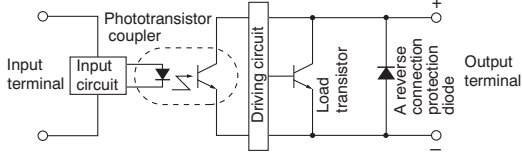

DIMENSIONS (mm inch)

Download [CAD Data](#) from our Web site.

[CAD Data](#)

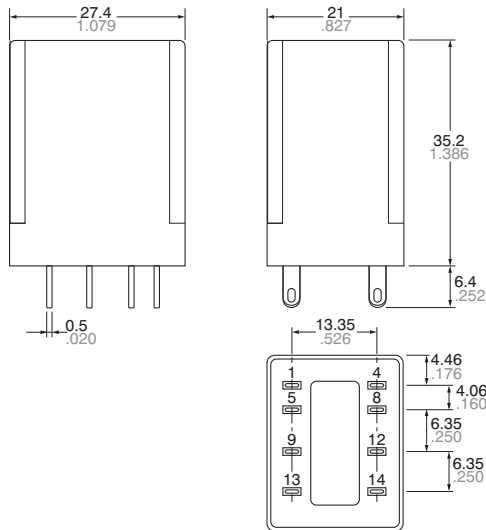

Terminal connection diagram (Bottom view)

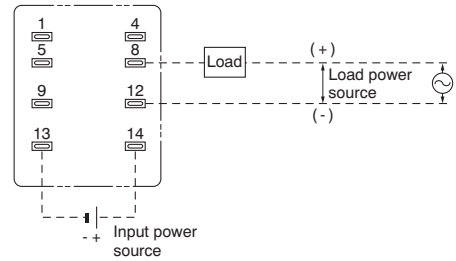

AQ-F SOLID STATE RELAY ACCESSORIES

Socket of HC relay is available for AQ-F solid state relay.

1. Socket for plug-in type

HC2 socket

[CAD Data](#)



HC2-SS-K

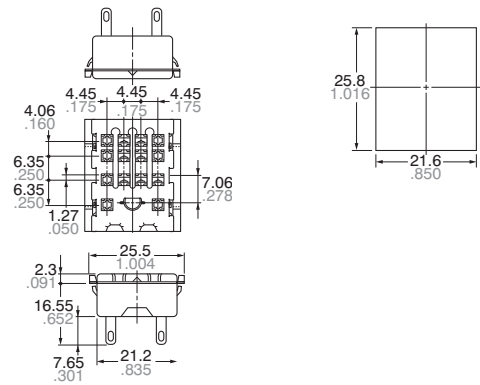
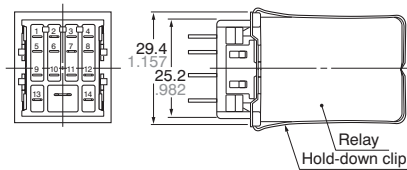

Tolerance: $\pm 0.1 \pm .004$

Note: HC3-SS-K and HC4-SS-K can be also used.

⚠ Not for new applications

2. Socket for PC board

HC2 socket for PC board

CAD Data



HC2-PS-K

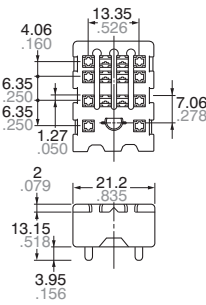
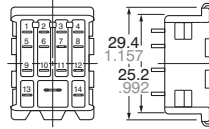

PC board pattern (Bottom view)

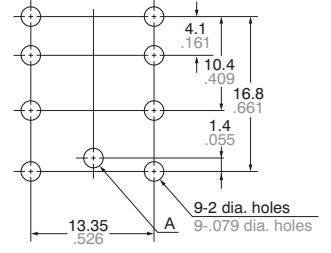

Tolerance: $\pm 0.1 \pm .004$

Note: HC3-PS-K and HC4-PS-K can be also used.

3. Wrapping socket

Standard wrapping socket

CAD Data

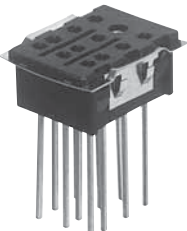

HC4-WS-K

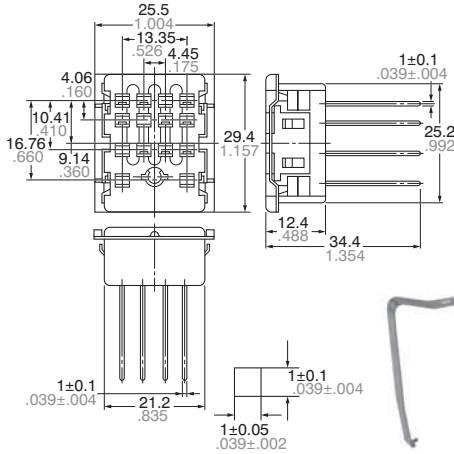

Wrapping socket with lock spring

CAD Data

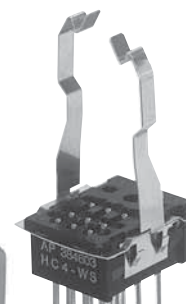

HC4-WS-L

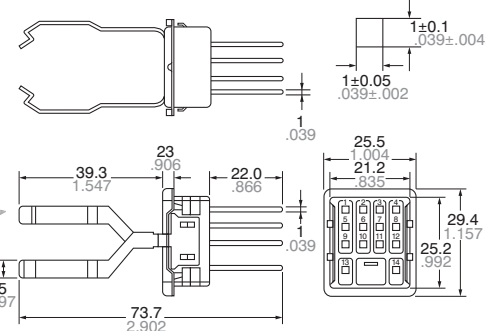

mm inch

4. DIN rail mounting socket

CAD Data

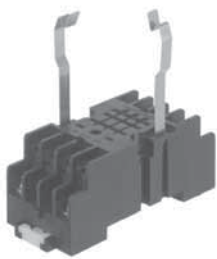

HC2-SFD-K

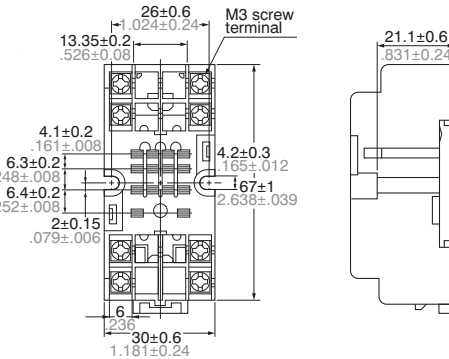

Schematic

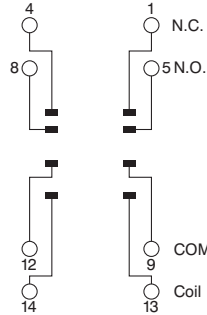

Mounting dimension (Bottom view)

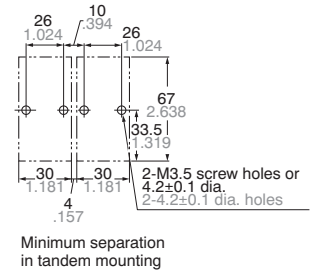

5. DIN socket for HC2-vertical type

CAD Data

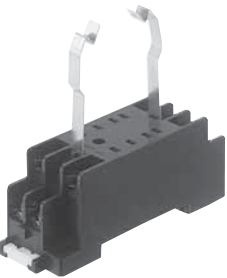

HC2-SFD-S

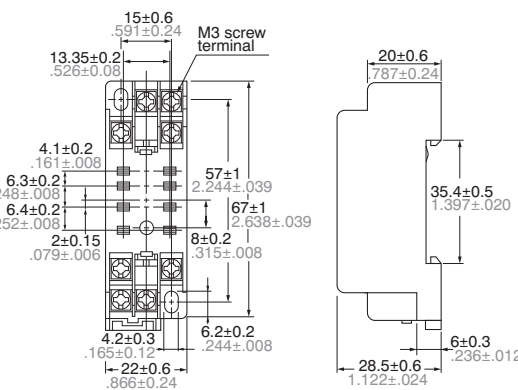

Schematic

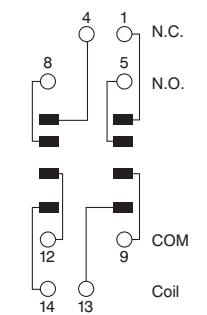

Mounting dimension (Bottom view)

