

M-DW1

Wafer Mapping Sensor



The industry's first safe LED beam reflective type wafer mapping sensor



Safe LEDs adopted

Laser mapping sensor is dangerous, because when mapping from inside the loading port, the laser beam which misses the FOUNDRY OVERHEAD UNIT (FOUP) is directed toward the operator. The **M-DW1** which uses a LED light source is much safer than the conventional laser beam mapping sensor.

Industry-first

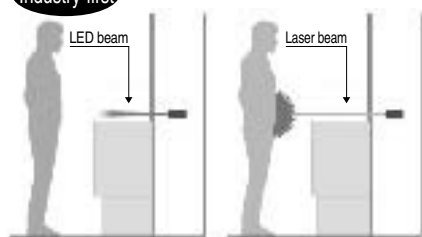

LED beam mapping sensor Laser beam mapping sensor

Glass wafers are also detectable

Recent trend shows a rapid increase of glass wafers. These wafers do not reflect much light and, therefore, their edge detection has been considered to be difficult. The **M-DW1**, which detects wafers not by the light amount but by the light position, can detect the glass wafers regardless of the light amount.

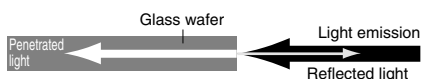

Sensing of nitride-coated wafers possible

Nitride-coated wafers absorb light at certain wavelengths depending on the coating thickness. If the sensor uses the laser beam having a single wavelength, the beam may be absorbed completely, resulting in wafer detection error. The **M-DW1** uses a LED light source with a wide wavelength band that allows it to detect nitride-coated wafers successfully.

High-speed response time: 0.5 ms

The sensor responds in 0.5 ms, meeting the requirements of both high speed and high accuracy in wafer detection.

4-way cable direction

The sensor cable can be drawn in any of the four directions; rearward, rightward, leftward and downward. This provides more flexibility in installation of the sensor.



Precise position detection by 2-segment receiving element

Wafer detection by the amount of reflected light may sometimes fail depending on the wafer edge shape. The **M-DW1** uses 2-segment receiving element in the beam-receiving part, and detects wafers by the reflected light position instead of the amount of reflected light. Thus, the sensor is less affected by wafer thickness or the amount of reflected light.

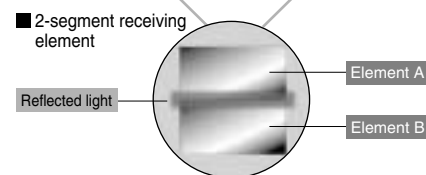

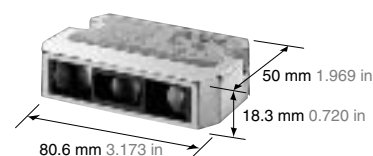

Compact and lightweight design with built-in amplifier

The sensor measures W80.6 mm × H18.3 mm × D50 mm W3.173 in × H0.720 in × D1.969 in, and weights only 75 g.



ORDER GUIDE

Appearance	Sensing range	Sensing object	Model No.	Output
	 45 mm 1.772 in	3 inch or larger semiconductor wafer	M-DW1	NPN output / PNP output selectable by switch

SPECIFICATIONS

Type	LED beam reflective type	
Item	Model No.	M-DW1
Center sensing distance	45 mm 1.772 in	
Sensing object	3 inch or larger semiconductor wafer (Note 1)	
Detectable surface	Surface having a side edge which reflects light in the light receiving direction (Note 2)	
Sensing angle	12.5 ± 5° (Note 3)	
Wafer pitch	Separate sensing is possible at normal sensitivity for 3 mm 0.118 in pitch or more (Note 4)	
Suitable cassette	SEMI standard FOUP cassette / open cassette	
Supply voltage	12 to 24 V DC ± 10 % Ripple P-P 10 % or less	
Current consumption	65 mA or less	
Output	NPN output / PNP output, selectable with output selection switch	
	<NPN output>	<PNP output>
	NPN open-collector transistor	PNP open-collector transistor
	<ul style="list-style-type: none"> • Maximum sink current: 100 mA • Applied voltage: 30 V DC or less (between output and 0 V) • Residual voltage: 1 V or less (at 100 mA sink current) 	<ul style="list-style-type: none"> • Maximum source current: 100 mA • Applied voltage: 30 V DC or less (between output and + V) • Residual voltage: 1 V or less (at 100 mA source current)
Utilization category	DC-12 or DC-13	
Output operation	Light-ON / Dark-ON, selectable by switch	
Short-circuit protection	Incorporated (restored automatically)	
Response time	500 μs or less	
Operation indicator	Orange LED (lights up when the output is ON)	
Stability indicator	Green LED (lights up under stable light received condition or stable dark condition)	
Timer function	Approx. 2 ms fixed OFF-delay timer, switchable either effective or ineffective	
Test input (emission halt input)	Signal condition <ul style="list-style-type: none"> • Emission Halt: Open, or 4 to 8 V • Emission: 0 to 3 V, or 9 V to + V (26.4 V max.) 	
Sensitivity selection input	Signal condition <ul style="list-style-type: none"> • Input OFF: Open, or 4 to 8 V • Input ON: 0 to 3 V, or 9 V to + V (26.4 V max.) 	
Sensitivity setting	Back surface teaching: effectuated with sensor's sensitivity setting button Detection sensitivity selection: 4 levels with sensor's 2 bit switch or 2 levels with external input selectable	
Environmental resistance	Pollution degree	3 (Industrial environment)
	Ambient temperature	0 to + 55 °C + 32 to + 131 °F (No dew condensation), Storage: - 10 to + 70 °C + 14 to + 158 °F
	Ambient humidity	35 to 85 % RH, Storage: 35 to 85 % RH
	Ambient illuminance	Incandescent light: 3,000 lx at the light-receiving face, Fluorescent light: 1,500 lx at the light-receiving face
	EMC	EN 50081-2, EN 50082-2, EN 60947-5-2
	Voltage withstandability	1,000 V AC for one min. between all supply terminals connected together and enclosure
	Insulation resistance	20 MΩ, or more, with 250 V DC megger between all supply terminals connected together and enclosure
	Vibration resistance	10 to 500 Hz frequency, 3 mm 0.118 in amplitude in X, Y and Z directions for two hours each
Shock resistance	98 m/s ² acceleration (10 G approx) in X, Y and Z directions for five times each	
Emitting element	LED (modulated)	
Material	Enclosure: ABS and Stainless steel (SUS301), Lens: Acrylic	
Cable	0.15 mm ² 5-core cabtyre cable, 300 mm 11.811 in long	
Cable extension	Extension up to total 10 m 32.808 ft is possible with 0.15 mm ² , or more, cable.	
Weight	75 g approx.	

- Notes: 1) In case of 8 inch or less wafers, the wafer pitch orientation flat or the surface condition may affect the sensing.
 2) Polished wafers, etc., which have a sharp edge cannot be detected since they do not reflect the light in the light receiving direction.
 3) Since the position of the orientation flat may vary by ± 20° due to its rotation, refer to '**Detecting wafer having orientation flat**'.
 4) This is the pitch of an 8 inch wafer near its center region when it is inserted in an inclined fashion. When detecting a wafer having an orientation flat, the wafer pitch becomes still smaller when sensing at positions which avoid the orientation flat. In this case, the sensing signal cannot be resolved and it becomes a continuous, broad signal.

M-DW1

I/O CIRCUIT AND WIRING DIAGRAMS

NPN output

I/O circuit diagram

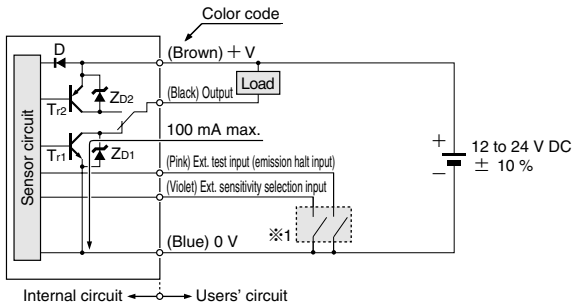

Symbols... D: Reverse supply polarity protection diode
 ZD1, ZD2: Surge absorption zener diode
 T11: NPN output transistor
 T12: PNP output transistor

Wiring diagram

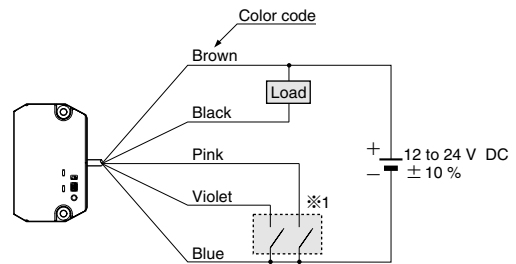

※1

Non-voltage contact or NPN open-collector transistor

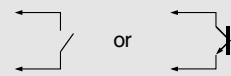

- External test input (emission halt input)
 0 to 3 V, or 9 V to + V (26.4 V max.): Emission halt
 Open, or 4 to 8 V: Emission
- External sensitivity selection input
 0 to 3 V, or 9 V to + V (26.4 V max.): Input ON
 Open, or 4 to 8 V: Input OFF

PNP output

I/O circuit diagram

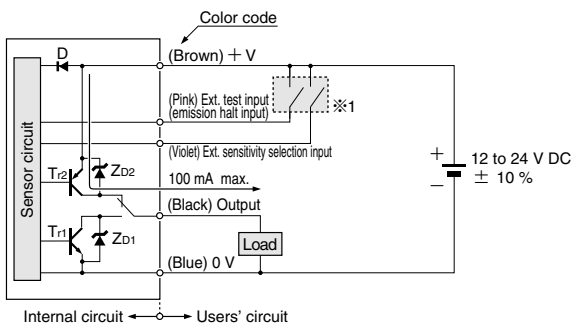

Symbols... D: Reverse supply polarity protection diode
 ZD1, ZD2: Surge absorption zener diode
 T11: NPN output transistor
 T12: PNP output transistor

Wiring diagram

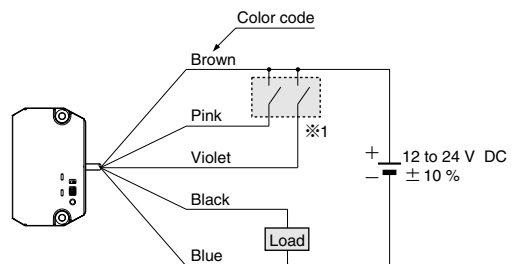

※1

Non-voltage contact or PNP open-collector transistor

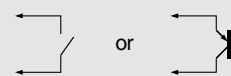

- External test input (emission halt input)
 0 to 3 V, or 9 V to + V (26.4 V max.): Emission halt
 Open, or 4 to 8 V: Emission
- External sensitivity selection input
 0 to 3 V, or 9 V to + V (26.4 V max.): Input ON
 Open, or 4 to 8 V: Input OFF

PRECAUTIONS FOR PROPER USE



This product is not a safety sensor. Its use is not intended or designed to protect life and prevent body injury or property damage from dangerous parts of machinery. It is a normal object detection sensor.

Mounting

- Set the distance between the sensor detection surface and the wafer edge to be 45 mm 1.772 in and mount the sensor so that sensing is done at an angle of 12.5° with respect to the wafer. Mount using M4 (length 16 mm 0.630 in) screws. The tightening torque should be 1.2 N·m or less. Further, although the sensing distance may change due to variation in the wafer position (wafer protrusion, orientation flat position, etc.), if it is within 5 mm 0.197 in, stable sensing is possible.

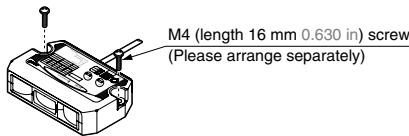

Top-view

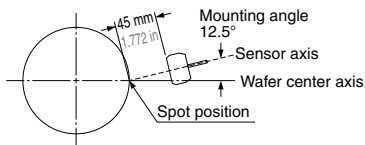

Note: If the wafer center axis and the sensor axis lie along a straight line (0°), detection is not possible. Always mount the sensor at an angle to the wafer.

Wiring

- Make sure that the power supply is off while wiring.
- Take care that wrong wiring will damage the sensor.
- Verify that the supply voltage variation is within the rating.
- If power is supplied from a commercial switching regulator, ensure that the frame ground (F.G.) terminal of the power supply is connected to an actual ground.
- In case noise generating equipment (switching regulator, inverter motor, etc.) is used in the vicinity of this product, connect the frame ground (F.G.) terminal of the equipment to an actual ground.
- Extension up to total 10 m 32.808 ft is possible with 0.15 mm² or more, cable. However, in order to reduce noise, make the wiring as short as possible.
- Do not run the wires together with high-voltage lines or power lines or put them in the same raceway. This can cause malfunction due to induction.
- Make sure to use an isolation transformer for the DC power supply. If an auto-transformer (single winding transformer) is used, this product or the power supply may get damaged.
- In case a surge is generated in the used power supply, connect a surge absorber to the supply and absorb the surge.

Others

- Do not use during the initial transient time (0.5 sec.) after the power supply is switched on.
- Take care that the sensor is not directly exposed to fluorescent light from a rapid-starter lamp or a high frequency lighting device, as it may affect the sensing performance.
- Avoid dust, dirt, and steam.
- Take care that the sensor does not come in direct contact with water, oil, grease, or organic solvents, such as, thinner, etc.
- Take care that dust, etc., does not collect on the sensing surfaces, as it may result in malfunction. Should it collect, clean the sensing surfaces by blowing air or wiping them gently with a soft cloth.

Detecting wafer having orientation flat

- When detecting a wafer having an orientation flat, mount the sensor so that a portion other than the orientation flat is detected. Further, arrange to detect the wafer from two different angles by moving the robot arm, etc., and OR the signal so obtained.

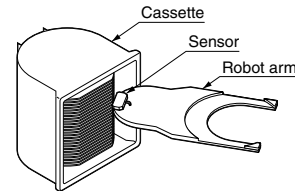

Top-view

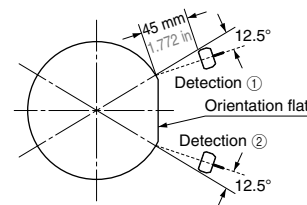

Part description

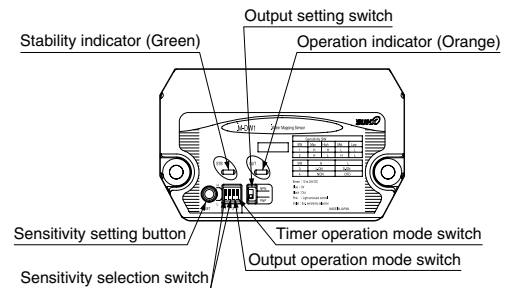

Sensitivity selection setting

- Sensitivity can be selected from four levels by appropriate setting of the sensitivity selection switch (2 bit).





Sensitivity selection switch	Sensitivity	
	Maximum sensitivity (MAX)	Used for low reflectivity wafers with nitride or oxide film processing, or for thin wafers (0.3 to 0.4 mm 0.012 to 0.016 in)
	High sensitivity (HIGH)	Sensitivity between maximum sensitivity and medium sensitivity
	Medium sensitivity (MID)	Used for high reflectivity polished wafers, etc., or for 3 mm 0.118 in wafer pitch
	Low sensitivity (LOW)	Lowest possible sensitivity setting

M-DW1

PRECAUTIONS FOR PROPER USE

External sensitivity selection input

- The external sensitivity selection input (violet) becomes ON when it is connected to 0 to 3 V, or 9 V to + V (26.4 V max.), and becomes OFF when it is kept open or connected to 4 to 8 V.
- If the sensitivity is selected with the external sensitivity selection input, set the sensitivity selection switch as shown in the table below.

Sensitivity selection switch	Ext. sensitivity selection input	Sensitivity	
	ON	Maximum sensitivity (MAX)	Used for low reflectivity wafers with nitride or oxide film processing, or for thin wafers (0.3 to 0.4 mm 0.012 to 0.016 in)
	OFF	Medium sensitivity (MID)	Used for high reflectivity polished wafers, etc., or for 3 mm 0.118 in wafer pitch
	ON	High sensitivity (HIGH)	Sensitivity between maximum sensitivity and medium sensitivity
	OFF	Low sensitivity (LOW)	Lowest possible sensitivity setting

Sensitivity setting

- Although this sensor has an optical system which makes it difficult for the background to affect the detection, the background may have an effect when detecting small diameter wafers. Hence, if the background gets detected, or the stability indicator (green) lights off when the cassette has no wafers, sensitivity setting should be done so that the background does not have an effect. However, the sensitivity reduces when sensitivity setting is done.

Setting method

- Sensitivity setting is done when the background affects the detection. Press the sensitivity setting button in the actual environment where the sensor is to be used (place at which the background has an effect), but without any wafers being present.

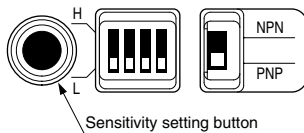

- The sensitivity is set at the time the sensitivity setting button is released. After the sensitivity setting, the output once turns into the detection state. If the sensitivity setting has been successfully done, the output turns to the non-detection state after 25 ms approx. and the sensitivity is set so that the background does not have an effect. In case the output remains in the detection state, since this is a condition in which detection cannot be done, readjust the sensitivity selection switch. In this case, set the sensitivity selection switch to one level higher sensitivity than the present sensitivity level. However, if the sensitivity selection switch is already at maximum sensitivity (MAX), move the background further away.
- If sensitivity setting is done with nothing in the background, the sensitivity returns to the initial value.
- Since the sensitivity is stored in an EEPROM when the sensitivity setting button is pressed, the setting need not be repeated when the power is switched on again. However, note that the EEPROM has a lifetime and its guaranteed life is 100,000 write operation cycles.

Test input (emission halt) function

- Light emission is halted when the external test input (emission halt input) (pink) is connected to 0 to 3 V, or 9 V to + V (26.4 V max.). In this case, the output turns to the dark state.

Time chart

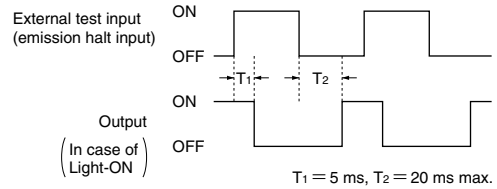

Timer function

- Using the timer operation mode switch, it is possible to select an approx. 2 ms fixed OFF-delay timer. Since the output is extended by a fixed period, it is useful when the connected device has a slow response time.

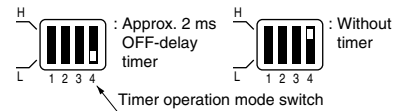

Time chart

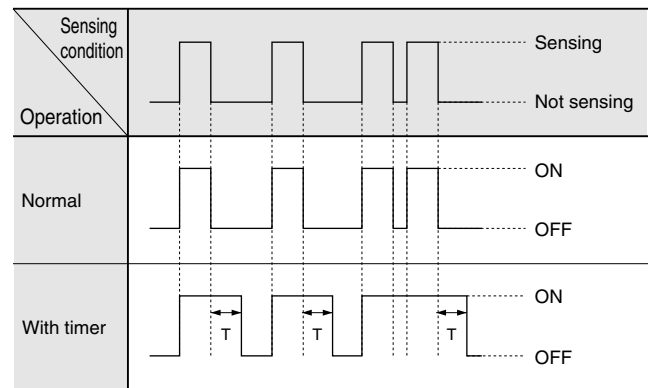

PRECAUTIONS FOR PROPER USE

Sensing signal

Sensing signal width

- The sensing signal which is output from the sensor is as follows:
 - The sensing signal has a width larger than the thickness of the wafer.
 - The signal width also varies with the reflectivity of the sensing edge.

High reflectivity (polish, aluminum evaporated, etc.): Large signal width
 Example: Wafer thickness $t = 0.6 \text{ mm } 0.024 \text{ in}$ → Signal width $1.5 \text{ mm } 0.059 \text{ in}$ approx.

Low reflectivity (nitride or oxide film processed): Small signal width
 Example: Wafer thickness $t = 0.6 \text{ mm } 0.024 \text{ in}$ → Signal width $1.1 \text{ mm } 0.043 \text{ in}$ approx.
 - The signal width also changes with the sensing distance or the sensing angle.

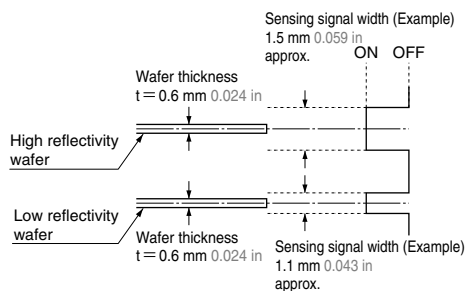

- From the above, for determining the position of the wafer from the sensing signal, calculate the center position of the signal's ON region, while taking into consideration the response time.

Narrow pitch sensing signal width

- In case of 'Detecting wafer having orientation flat', when the sensor is mounted at positions which avoid the wafer orientation flat, the pitch of a cross-condition wafer changes as shown in the figure below.

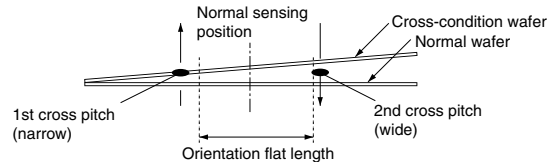

- The calculated pitch based on the wafer size is given in the table below.

Wafer size	Normal pitch	Orienta-tion flat length	Wafer thickness	Cross pitch (narrow)	Cross pitch (wide)
3 inch (75 mm 2.953 in)	4.75 mm 0.187 in	22.2 mm 0.874 in	0.380 mm 0.015 in	1.58 mm 0.062 in	3.17 mm 0.125 in
4 inch (100 mm 3.937 in)	4.75 mm 0.187 in	32.5 mm 1.280 in	0.625 mm 0.025 in	1.54 mm 0.061 in	3.21 mm 0.126 in
5 inch (125 mm 4.921 in)	4.75 mm 0.187 in	42.5 mm 1.673 in	0.625 mm 0.025 in	1.52 mm 0.060 in	3.23 mm 0.127 in
6 inch (150 mm 5.906 in)	4.75 mm 0.187 in	57.5 mm 2.264 in	0.675 mm 0.027 in	1.43 mm 0.056 in	3.33 mm 0.131 in
8 inch (200 mm 7.874 in)	6.35 mm 0.250 in	59.3 mm 2.335 in	0.725 mm 0.029 in	2.19 mm 0.086 in	4.16 mm 0.164 in

- From the above, it is seen that, since the pitch of the cross-condition wafer reduces, the pitch resolution required for high reflectivity wafers becomes more stringent than the specified resolution of 3 mm 0.118 in. Hence, the sensing signal from two wafers may not be resolved and may become a continuous signal. Further, the sensing signal may also change due to the sensitivity setting, the reflectivity of the wafer, and the sensing conditions (sensing distance or sensing angle). For the above reasons, in case of wafers which have been cross-inserted, since the small cross-pitch side is similar to overlapping wafers, the sensing signal of two wafers may become a continuous signal or may get resolved.
- If the orientation flat happens to get in the position of sensing, sensing is not possible in one of the two sensing positions. Therefore, if the wafer is cross-inserted, a resolved signal may not be output, and in this case, the information on the wafer position calculated from the sensing signal will be erroneous.

DIMENSIONS (Unit: mm in)

