

Density mounting

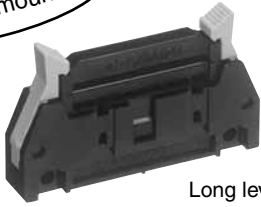

Long lever type

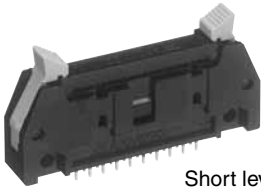

Short lever type

FEATURES

1. High density mounting is possible.
Even with mounting right next to another connector, insertion into and removal from the socket can be done, providing a saving in the surface mounting space.

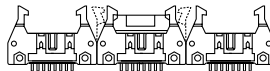

2. Lever with original stopper construction for great strength
The original stopper construction reduces the possibility of lever damage even when excess load is applied to the lever during socket insertion and removal, and during transportation.

3. Metal pin-less lever construction
Noise prevention is considered in this construction by not using metal pins, which, if present, act as noise absorbing antennas.

4. Incorrect insertion prevention mechanism.
Because of the box type construction of the header and the special key that is used, incorrect insertion can be prevented. Also, by means of the special key that is used, incorrect insertion into an adjacent connector is prevented.



Compliance with RoHS Directive

ORDERING INFORMATION

1. Socket

1: MIL connectors (Socket)

<No. of contacts (2 digits)>

10: 10 contacts 14: 14 contacts 16: 16 contacts 20: 20 contacts 26: 26 contacts 30: 30 contacts
34: 34 contacts 40: 40 contacts 50: 50 contacts 60: 60 contacts 64: 64 contacts

<Strain relief/Polarity guide>

0: Without strain relief/10 contacts: with polarity guide
2: Without strain relief/Min. 14 contacts with polarity guide, 10 contacts without polarity guide
4: With strain relief/14 contacts with polarity guide, 10 contacts without polarity guide
9: With strain relief/10 contacts: with polarity guide

<Pitch of flat cable>

1: 1.27 mm

<Surface treatment (Contact portion/Terminal portion)>

5: Au plating/Au plating

AXM 1 1 5

2. Header

2: MIL connectors (Header)

<No. of contacts (2 digits)>

10: 10 contacts 14: 14 contacts 16: 16 contacts 20: 20 contacts 26: 26 contacts 30: 30 contacts
34: 34 contacts 40: 40 contacts 50: 50 contacts 60: 60 contacts 64: 64 contacts

<Lever shape>

0: Long lever
1: Short lever
2: Without lever

<Terminal shape/Polarity slot>

0: Straight (Min. 14 contacts with polarity slot, 10 contacts without polarity slot)
1: Angle (Min. 14 contacts with polarity slot, 10 contacts without polarity slot)
8: Straight (10 contacts with polarity slot)
9: Angle (10 contacts with polarity slot)

<Surface treatment (Contact portion/Terminal portion)>

1: Au plating/Sn plating

AXM 2 1

3. Strain relief



3: MIL connectors (Strain relief)

<No. of contacts (2 digits)>

10: 10 contacts 14: 14 contacts 16: 16 contacts 20: 20 contacts 26: 26 contacts 30: 30 contacts
 34: 34 contacts 40: 40 contacts 50: 50 contacts 60: 60 contacts 64: 64 contacts

SPECIFICATIONS

1. Characteristics

Item		Specifications	Conditions
Electrical characteristics	Rated current	1 A When the header is connected to our wire-press socket, the rated current varies depending on the wire used as shown below. (AWG#23/#24: 3 A, AWG#26: 2 A, AWG#28: 1 A)	
	Breakdown voltage	750 V AC for 1 min.	Detection current: 1 mA
	Insulation resistance	Min. 1000MΩ	at 500V DC megger
	Contact resistance	Max. 20mΩ	Measured based on the HP4338B measurement method of JIS C 5402
Mechanical characteristics	Unit removal force	Min. 0.785N {80gf}/2 contacts	Measured by steel-pin-gauge with (0.64±0.01) × (0.64±0.01)mm ² cross section area.
	Composite insertion force	Max. 2.94N {300gf} × no. of contacts	
	Post holding force	Min. 19.6N {2kgf}	By pulling post until coming off
	Lever locking strength	Min. 78.5N {8kgf}	Sockets are pulled to the derrection of shaft in the mated condition
	Cover strength	Min. 78.5N {8kgf}	By pulling protector or strain relief to the direction of shaft
Lifetime characteristics	Insertion and removal life	500 times	
	Ambient temperature	-55° to +105°C	
Environmental characteristics	Vibration resistance	10 to 55Hz at the double amplitude of 1.52mm	No opening more than 1μsec. at max. 100mA carrying current
	Shock resistance	490m/s ² {50G}	No opening more than 1μsec. at max. 100mA carrying current

2. Materials and surface treatment

Part name	Material	Surface
Molded portion	Glass reinforced PBT (UL94V-0)	—
Contact (Socket)	Copper alloy	Contact portion: Ni plating on base, Au plating on surface Pressured portion: Ni plating on base, Au plating on surface
Post (Header)	Copper alloy	Contact portion: Ni plating on base, Au plating on surface Terminal portion: Ni plating on base, Sn plating on surface

3. Applicable cable

Standard wire	AWG28 Pitch 1.27mm
---------------	--------------------

PRODUCT TYPES

1. Socket

No. of contacts	No. of polarity guide	Without strain relief	With strain relief
10	0	AXM110215	AXM110415
	1	AXM110015	AXM110915
14	1	AXM114215	AXM114415
16	1	AXM116215	AXM116415
20	1	AXM120215	AXM120415
26	1	AXM126215	AXM126415
30	1	AXM130215	AXM130415
34	1	AXM134215	AXM134415
40	1	AXM140215	AXM140415
50	1	AXM150215	AXM150415
60	1	AXM160215	AXM160415
64	1	AXM164215	AXM164415

2. Strain relief

No. of contacts	Part No.
10	AXM310
14	AXM314
16	AXM316
20	AXM320
26	AXM326
30	AXM330
34	AXM334
40	AXM340
50	AXM350
60	AXM360
64	AXM364

AXM

3. Header

No. of contacts	No. of polarity slot	Long lever type		Short lever type	
		Angle	Straight	Angle	Straight
10	0	AXM210011	AXM210001	AXM210111	AXM210101
	1	AXM210091	AXM210081	AXM210191	AXM210181
14	1	AXM214011	AXM214001	AXM214111	AXM214101
16	1	AXM216011	AXM216001	AXM216111	AXM216101
20	1	AXM220011	AXM220001	AXM220111	AXM220101
26	1	AXM226011	AXM226001	AXM226111	AXM226101
30	1	AXM230011	AXM230001	AXM230111	AXM230101
34	1	AXM234011	AXM234001	AXM234111	AXM234101
40	1	AXM240011	AXM240001	AXM240111	AXM240101
50	1	AXM250011	AXM250001	AXM250111	AXM250101
60	1	AXM260011	AXM260001	AXM260111	AXM260101
64	1	AXM264011	AXM264001	AXM264111	AXM264101

Notes) 1. A no-lever type is available. This product will be manufactured after receiving your order. Please inquire about delivery.

When ordering change the fourth digit in the part number to "2".

2. The tray packing quantity for outer carton is 200 pcs.

3. For the available foreign standard products, refer to "STANDARDS CHART" on the end of the catalog.

4. Keys

Product name	Part No.
Polarity key	AXM8001
Incorrect insertion prevention key	AXM8002

DIMENSIONS (Unit: mm)

The CAD data of the products with a **CAD Data** mark can be downloaded from: <http://www.mew.co.jp/ac/e>

• Socket

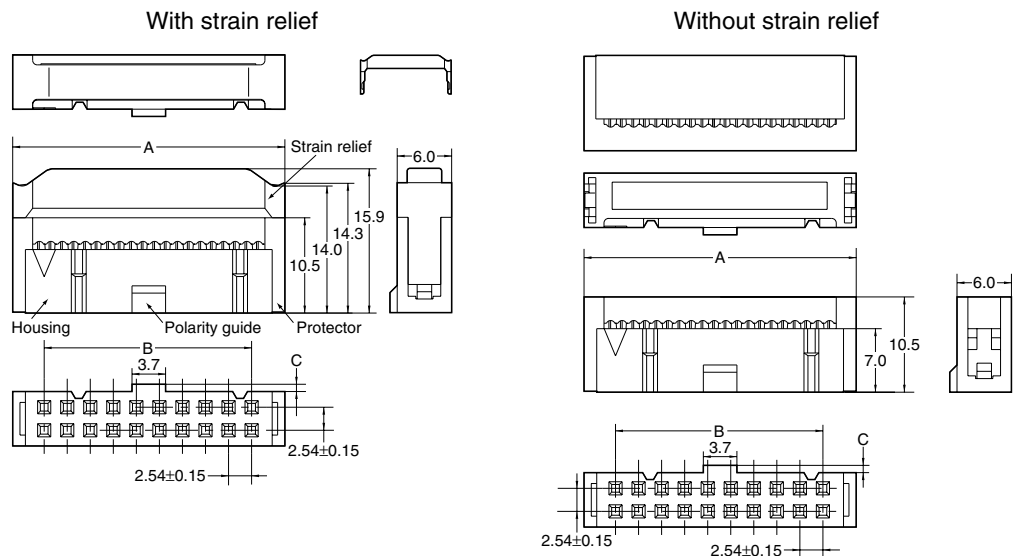

Dimension table (mm)

No. of contacts	No. of Polarity slot	A	B	C
10	0	17.3	10.16	—
	1	17.3	10.16	—
14	1	22.4	15.24	0.8
16	1	24.9	17.78	
20	1	30.0	22.86	1.0
26	1	37.6	30.48	
30	1	42.7	35.56	1.4
34	1	47.8	40.64	
40	1	55.4	48.26	1.4
50	1	68.1	60.96	
60	1	80.8	73.66	1.4
64	1	85.9	78.74	

Cross section view

With strain relief

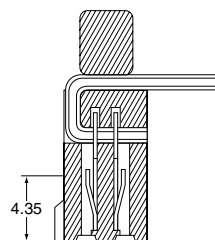

Without strain relief

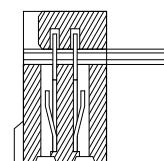

General tolerance: ±0.3

• Header (Long lever type)

CAD Data

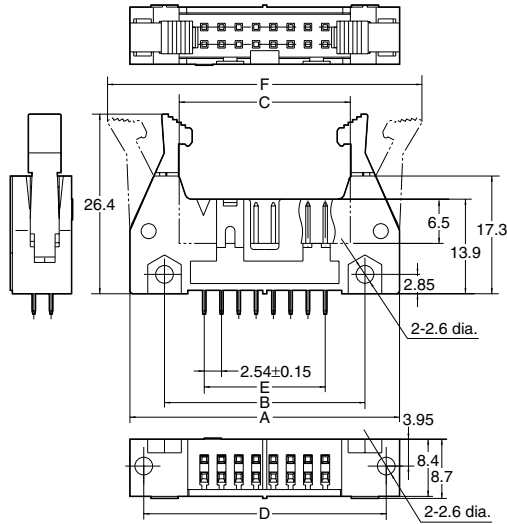

General tolerance: ±0.3

Dimension table (mm)

No. of contacts	No. of Polarity slot	A	B	C	D	E	F
10	0	32.0	21.84	17.53	27.9	10.16	38.6
	1	32.0	21.84	17.53	27.9	10.16	38.6
14	1	37.1	26.92	22.61	33.0	15.24	43.7
16	1	39.6	29.46	25.15	35.6	17.78	46.2
20	1	44.7	34.54	30.23	40.6	22.86	51.3
26	1	52.3	42.16	37.85	48.3	30.48	58.9
30	1	57.4	47.24	42.93	53.34	35.56	64.0
34	1	62.5	52.32	48.01	58.4	40.64	69.1
40	1	70.1	59.94	55.63	66.0	48.26	76.7
50	1	82.8	72.64	68.33	78.7	60.96	89.4
60	1	95.5	85.34	81.03	91.4	73.66	102.1
64	1	100.6	90.42	86.11	96.5	78.74	107.2

Terminal dimensions
Angle terminal Straight terminal

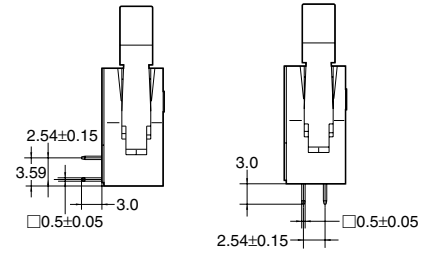

Recommended PC board pattern
(BOTTOM VIEW)

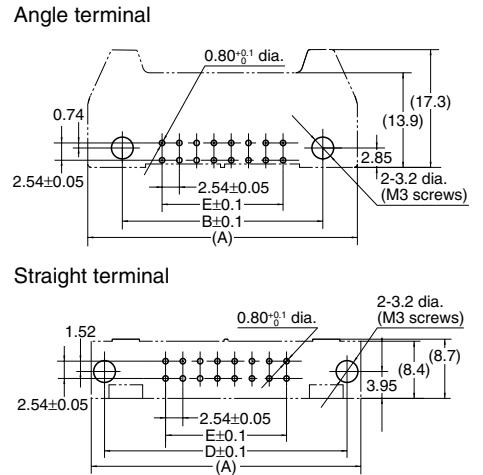

Note) Dimensions of A, B, D and E are the same as the header dimensions.

• Header [Short lever]

CAD Data

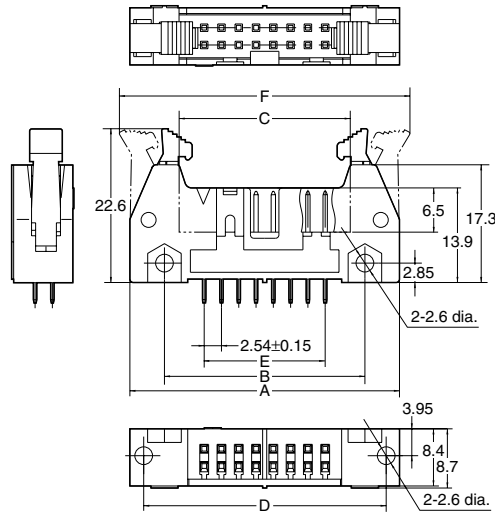
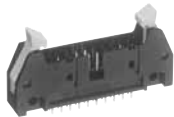

General tolerance: ±0.3

Dimension table (mm)

No. of contacts	No. of Polarity slot	A	B	C	D	E	F
10	0	32.0	21.84	17.53	27.9	10.16	35.0
	1	32.0	21.84	17.53	27.9	10.16	35.0
14	1	37.1	26.92	22.61	33.0	15.24	40.1
16	1	39.6	29.46	25.15	35.6	17.78	42.7
20	1	44.7	34.54	30.23	40.6	22.86	47.7
26	1	52.3	42.16	37.85	48.3	30.48	55.4
30	1	57.4	47.24	42.93	53.34	35.56	60.4
34	1	62.5	52.32	48.01	58.4	40.64	65.5
40	1	70.1	59.94	55.63	66.0	48.26	73.1
50	1	82.8	72.64	68.33	78.7	60.96	85.8
60	1	95.5	85.34	81.03	91.4	73.66	98.5
64	1	100.6	90.42	86.11	96.5	78.74	103.6

Terminal dimensions
Angle terminal Straight terminal

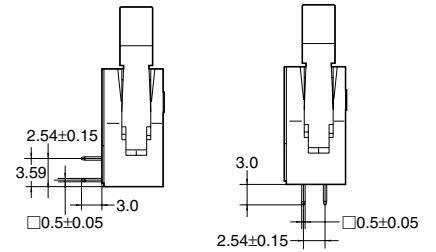

Recommended PC board pattern
(BOTTOM VIEW)

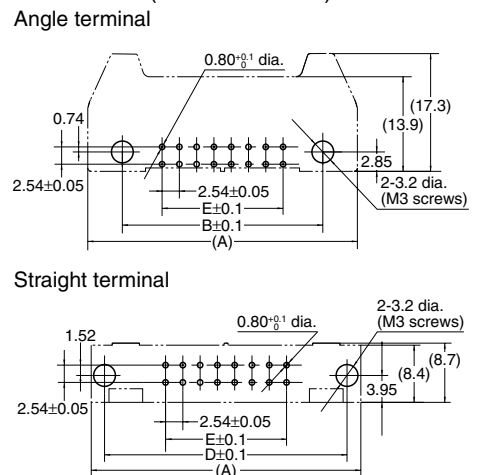

Note) Dimensions of A, B, D and E are the same as the header dimensions.

AXM

CABLE NO. AND TERMINAL POSITION CORRELATION DRAWING

Socket

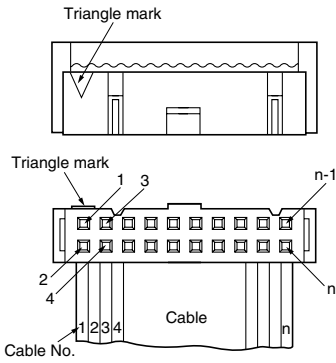

Header (Angle terminal)

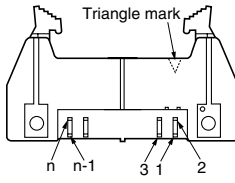

Header (Straight terminal)

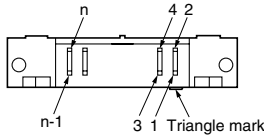

Terminal numbers are not indicated on the connector. Using the triangle mark as reference, the connection operations and printed circuit board design should be carried out.

When the cable numbers are temporarily assigned from the end as 1, 2, 3, 4 ... n, the corresponding terminal number positions for the socket are as shown in the drawing on the left. The header terminal positions and corresponding positions are shown in the drawing on the left.

COMBINATION OF HEADER AND SOCKET

With strain relief

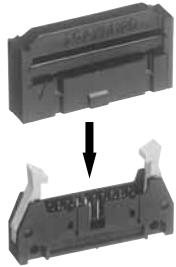

Long lever type

Without strain relief

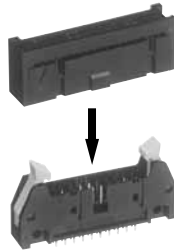

Short lever type

	Header	Long lever type	Short lever type
Socket			
Strain relief		Good	Not good
Without strain relief		Not good	Good

REGARDING REVERSE AND INCORRECT INSERTION PREVENTION

1. Reverse insertion prevention mechanism

The header polarity slot and socket polarity guide of these MIL connectors make for a construction which prevents reverse insertion. (However, the 10-contact type does not feature this construction.)

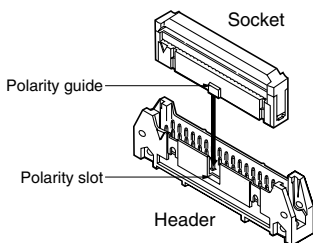

2. Polarity key (AXM8001) for double prevention of reverse insertion

Reverse insertion is doubly prevented by inserting the polarity key (AXM8001) into the header to create a projection and by aligning this projection with the cutout in the socket.

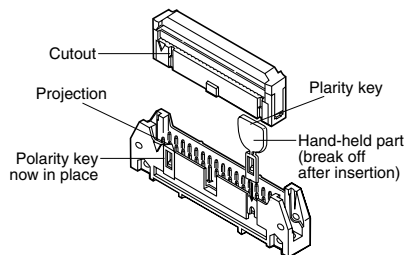

3. Incorrect insertion prevention key (AXM8002) ideal for preventing incorrect insertion into adjacent connectors when a multiple number of MIL connectors with the same number of contacts are used

Incorrect insertion is prevented by plugging the hole in the socket with the incorrect insertion prevention key (AXM8002) and then by removing or cutting off the pin of the corresponding header.

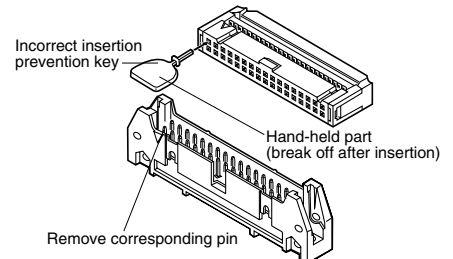

NOTES

1. Regarding design of printed circuit board

The connector terminal numbers are not indicated. Using the triangle mark as reference, the printed circuit board design and the cable connection operations can be carried out.

2. Regarding insertion into and removal from the socket

When inserting or removing the connector, be careful not to pull the cable. Hold the socket by hand to remove the connector when the no-lever type is used. With the lever type header, removal is easy.

When the socket is unconnected, be careful not to apply excessive force to the levers.

3. Regarding external force applied to the cable

When there is the possibility that external force may be applied to the cable, or in the case of vibration being applied to the connector cable, a strain relief socket should be used.

4. Regarding soldering of the header

Soldering should be carried out under the conditions given below.

260°C: Within 10 seconds

300°C: Within 5 seconds

350°C: Within 3 seconds

5. Regarding the handling of header terminals

Care should be taken with the header terminals because repeated bending of the terminals can lead to damage.

6. Regarding the cable pressure connection tool

The special tool provided by our company for cutting the cable and making the pressure connections should be used.

7. Regarding the selection of header type

When making the selection of the header, the following factors should be used for the selection.

Condition Header	Repeated vibration and shock	Occasional vibration and shock	Force used on cable
Long lever type	Very good	Very good	Very good
Short lever type	Good	Good	Not good

Note) Vibration: 9.8 m/s² {1G}/10 to 150 Hz
Shock: 49 m/s² {5G}

The above should be considered as criteria.

For other details, please verify with the product specification sheets.