

AJ8 switch standard actuator



AJ8 switch Wide actuator



RoHS Directive compatibility information
<http://www.nais-e.com/>

FEATURES

1. Power rocker switches for safety requirements.

- All versions comply with Class II EN61058-1 insulation grade. Insulation distance: 8mm Min. Contact gap: 3mm Min.

¥ International Standard-approved status

		Already approved
AJ8 switch	Standard actuator type	UL, CSA, VDE, TÜV, ÖVE, KEMA, SEMKO, NEMKO, DEMKO, FIMKO, SEV
	Wide actuator type	UL, CSA, VDE, TÜV, SEMKO, NEMKO, DEMKO, FIMKO, SEV, KEMA, ÖVE

2. High inrush current resistance is ideal for office automation equipment.

Type	Inrush	Contact rating	Expected life
AJ8	160A	16A 250V AC	Min.10 ⁴

3. Operation that only requires a light touch

The best operation characteristics were sought by analyzing touch data gathered by monitoring 1,500 people.

- Power Rocker Switch touch curve

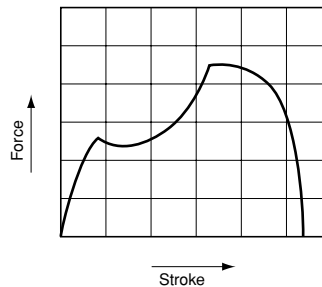

4. A broad product line

The AJ8 switches are available with five different types of terminals: quick-connect terminals, soldering terminals, PC board terminals, right angle terminals and left angle terminals.

5. Eight standard actuator colors

White, black, red, dark gray, light gray, blue, green, yellow

6. Cadmium-free contact compatibility.

PRECAUTIONS WHEN USING CADMIUM-FREE CONTACT TYPE

Models with cadmium-free contacts have been introduced in order to reduce environmentally harmful substances. ("F" is affixed to the end of the part number.) We ask customers who are currently using products with cadmium-containing contacts (no "F" at the end of the part number) to please make the switch to models with cadmium-free contacts. When switching, operating life may differ depending on the load. Please be sure to verify this by conducting an evaluation using actual equipment.

CONSTRUCTION

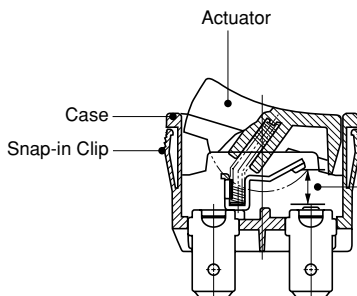

Contact gap (more than 3mm)

The EN60950 (intended for office automation equipment) conforms with a 3mm gap. When directly opening or closing the primary power supply side, a contact gap of at least 3mm is required in order to ensure safety.

AJ8 (J8)

ORDERING INFORMATION

	AJ	8	□	□	□	□	□	□	□	F
8: AJ8 switch										
Nil: Standard actuator W: Wide actuator										
Number of poles and Operation 1: 1-pole, single throw (ON-OFF) 2: 2-pole, single throw (ON-OFF)										
Terminal shape 0: .250 Quick-connect terminal 1: Soldering terminal 2: PC board terminal 3: PC board right angle terminal (for standard actuator only) 4: PC board left angle terminal (for standard actuator only)										
Actuator indication 0: No indication 1: <input type="checkbox"/> indication 2: <input type="checkbox"/> indication										
Actuator color W: White B: Black R: Red Z: Dark gray H: Light gray L: Blue G: Green Y: Yellow										
Flange color Nil: Black (standard color) (Custom ordered color: W: White, R: Red, Z: Dark gray, H: Light gray, L: Blue, G: Green, Y: Yellow) <small>Remark 1)</small>										
Insulation guard Nil: Short guard type T: Long guard type (.250 Quick-connect terminal and soldering terminal of standard actuator only)										
F: Cadmium-free product										

Remarks: 1. Please consult us for details concerning different flange colors.
2. "I O" is engraved on all flanges.
3. The color of indication on the actuator:
• White actuator: black
• Others: white

PRODUCT TYPES

1. Standard actuator type

(1) Without indication on actuators

Terminal shape	Poles	Operating types	Part No.
			Without indication
.250 Quick-connect terminal	1-pole	ON-OFF	AJ8100*F
	2-pole		AJ8200*F
Soldering terminal	1-pole		AJ8110*F
	2-pole		AJ8210*F
PC board terminal	1-pole		AJ8120*F
	2-pole		AJ8220*F
PC board right angle terminal	1-pole		AJ8130*F
	2-pole		AJ8230*F
PC board left angle terminal	1-pole		AJ8140*F
	2-pole		AJ8240*F

Remarks: 1. A letter indicating the actuator color is entered in place of asterisk. (W: White, B: Black, R: Red, Z: Dark gray, H: Light gray, L: Blue, G: Green, and Y: Yellow). Standard flange color is black. For other colors type, they are custom ordered. For requests of other flange color, please enter the following letter before the "F" in the part number. (W: White, R: Red, Z: Dark gray, H: Light gray, L: Blue, G: Green and Y: Yellow)
2. Long guard type is available for .250 Quick-connect terminal and soldering terminal type. When ordering, please add a "T" before the "F" at the end of the part number.
3. The color of indication on the actuator:
• For white actuator: black
• For others: white
4. They come with a stamp indicating international standards without your request.
5. Note that the position of the I mark on the flange is used as a reference for left angle and right angle terminals as shown in the diagram below.



Right angle terminal



Left angle terminal

(2) With indication on actuators

Terminal shape	Poles	Operating types	Part No.	
			With ○ indication	With — ○ indication
.250 Quick-connect terminal	1-pole	ON-OFF	AJ8101*F	AJ8102*F
	2-pole		AJ8201*F	AJ8202*F
Soldering terminal	1-pole		AJ8111*F	AJ8112*F
	2-pole		AJ8211*F	AJ8212*F
PC board terminal	1-pole		AJ8121*F	AJ8122*F
	2-pole		AJ8221*F	AJ8222*F
PC board right angle terminal	1-pole		AJ8131*F	AJ8132*F
	2-pole		AJ8231*F	AJ8232*F
PC board left angle terminal	1-pole		AJ8141*F	AJ8142*F
	2-pole		AJ8241*F	AJ8242*F

- Remarks: 1. A letter indicating the actuator color is entered in place of asterisk. (W: White, B: Black, R: Red, Z: Dark gray, H: Light gray, L: Blue, G: Green, and Y: Yellow). Standard flange color is black. For other colors type, they are custom ordered. For requests of other flange color, please enter the following letter before the "F" in the part number. (W: White, R: Red, Z: Dark gray, H: Light gray, L: Blue, G: Green and Y: Yellow)
2. Long guard type is available for .250 Quick-connect terminal and soldering terminal type. When ordering, please add a "T" before the "F" at the end of the part number.
3. The color of indication on the actuator:
- For white actuator: black
 - For others: white
4. They come with a stamp indicating international standards without your request.
5. Note that the position of the | mark on the flange is used as a reference for left angle and right angle terminals as shown in the diagram below.

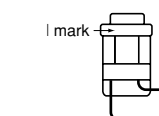

Right angle terminal



Left angle terminal

2.Wide actuator type

(1) Without indication on actuators

Terminal shape	Poles	Operating types	Part No.	
			Without indication	
.250 Quick-connect terminal	1-pole	ON-OFF	AJ8W100*F	
	2-pole		AJ8W200*F	
Soldering terminal	1-pole		AJ8W110*F	
	2-pole		AJ8W210*F	
PC board terminal	1-pole		AJ8W120*F	
	2-pole		AJ8W220*F	

(2) With indication on actuators

Terminal shape	Poles	Operating types	Part No.	
			With ○ indication	With — ○ indication
.250 Quick-connect terminal	1-pole	ON-OFF	AJ8W101*F	AJ8W102*F
	2-pole		AJ8W201*F	AJ8W202*F
Soldering terminal	1-pole		AJ8W111*F	AJ8W112*F
	2-pole		AJ8W211*F	AJ8W212*F
PC board terminal	1-pole		AJ8W121*F	AJ8W122*F
	2-pole		AJ8W221*F	AJ8W222*F

- Remarks: 1. A letter indicating the actuator color is entered in place of asterisk. (W: White, B: Black, R: Red, Z: Dark gray, H: Light gray, L: Blue, G: Green, and Y: Yellow). Standard flange color is black. For other colors type, they are custom ordered. For requests of other flange color, please enter the following letter before the "F" in the part number. (W: White, R: Red, Z: Dark gray, H: Light gray, L: Blue, G: Green and Y: Yellow)
2. The color of indication on the actuator:
- For white actuator: black
 - For others: white
3. They come with a stamp indicating international standards without your request.

SPECIFICATIONS**1. Contact rating**

Type	Voltage	Resistive load ($\cos \phi \approx 1.0$)	Motor load (EN61058-1) ($\cos \phi \approx 0.6$)
AJ8 switch	250V AC	16A	4A

Remark: The motor load is in accordance with EN61058-1. Inrush current can be switched up to the value of 6 times the indicated rating.

AJ8 (J8)

2. Characteristics

Expected life (Min. operations)	Mechanical	Min. 5×10^4 (at 20 cpm.)
	Electrical	Min. 10^4 (at 7 cpm., at rated load)
Initial insulation resistance (Between terminals)		Min. 100 M Ω (at 500V DC measured by insulation resistive meter)
Initial breakdown voltage (Between terminals)		2,000 Vrms detection current: 10 mA
Initial contact resistance (By voltage drop at 1A, 2 to 4V DC)		Max. 100m Ω
Temperature rise	at 6×10^3 ope. or less	Max. 30°C (UL1054)
	from 6×10^3 ope. to 10^4	Max. 55°C (EN61058-1)
Vibration resistance		10 to 55 Hz at double amplitude of 1.5mm
Shock resistance		Min. 490m/s ² {50 G}
Actuator strength		40 N {4.08kgf} for 1 minute (operating direction)
Terminal strength (.250 Quick-connect terminal)		100 N {10.2kgf} for 1 minute or more (Pull & push direction)
Ambient temperature		-25°C to +85°C (Not freezing below 0°C)
Flame retardancy		UL94V-0
Tracking resistance		Min. 175
Operating force (reference characteristics)	1-pole	$2.45 \pm 1.47\text{N}$ {0.25 \pm 0.15kgf}
	2-pole	$4.5 \pm 2.5\text{N}$ {0.46 \pm 0.25kgf}
Contact material		AgSnO ₂ alloy

Remark: Test conditions are in accordance with EN61058-1, UL1054 and JIS C 6571.

DIMENSIONS

mm General tolerance: ± 0.5

1. .250 Quick-connect terminal/Short guard type

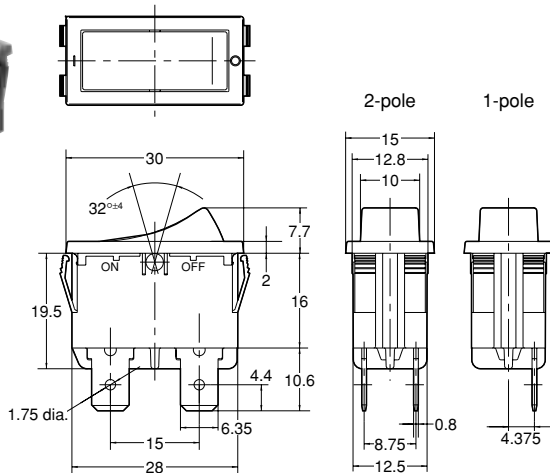

Long guard type
.250 Quick-connect terminal

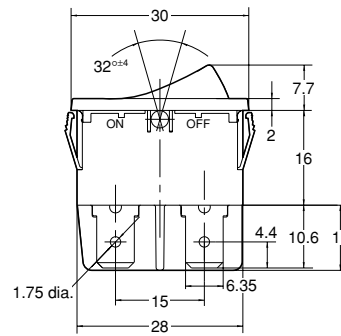
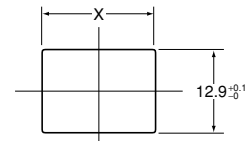
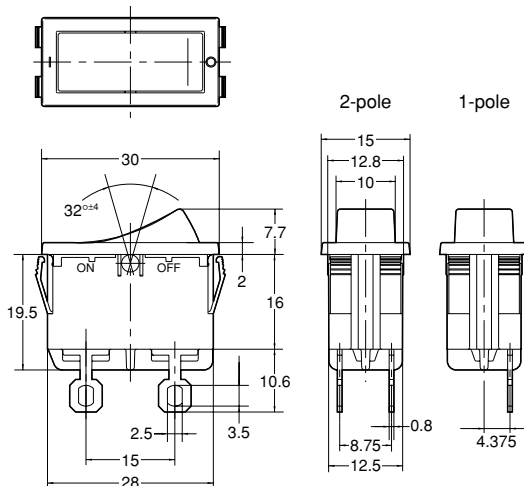

Diagram of recommended
locations for panel
mounting holes



Panel thickness	X
0.75 to 1.25	28.2 ^{+0.0} _{-0.1}
1.25 to 2	28.4 ^{+0.0} _{-0.1}
2 to 3	28.8 ^{+0.0} _{-0.1}

2. Soldering terminal



Long guard type
Soldering terminal

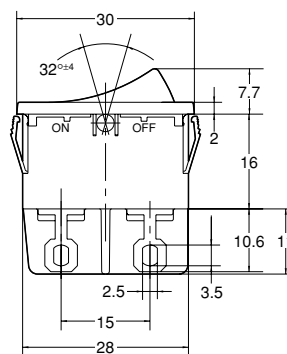
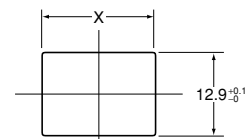

Diagram of recommended
locations for panel
mounting holes



Panel thickness	X
0.75 to 1.25	28.2 ^{+0.0} _{-0.1}
1.25 to 2	28.4 ^{+0.0} _{-0.1}
2 to 3	28.8 ^{+0.0} _{-0.1}

